

Isolated Converter

■ Features

- Multi-input
 - CN-610□-□: Thermocouple 12 types, RTD 5 types, analog (mV, V, mA) 6 types
 - CN-640□-□: 0 to 50.00kHz
- Improves visibility with negative LCD
 - : 12-segment, 3 colors (selectable red, green, yellow)
- Displays input type and unit on display part
- Various outputs
 - : 4, 2, 1 alarm output, 0-20mA transmission output (adjustable insulation, output range), 0-10VDC voltage output (adjustable insulation, output range)
- Various functions
 - : High/Low peak monitoring, sensor disconnection alarm output (burn-out), input correction, user input range, display scale, transmission output scale, analog output range setting
- Built-in power supply for sensor (24VDC)



! Please read "Safety Considerations" in the instruction manual before using.



■ Ordering Information

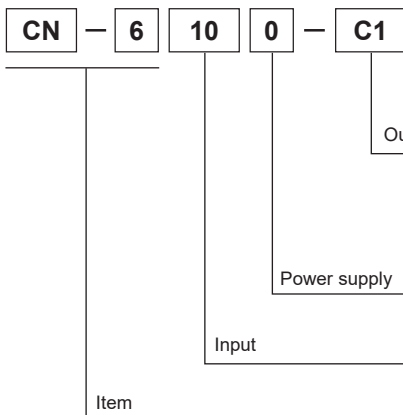

C1	Transmission output (0-20mA): 1
C2	Transmission output (0-20mA): 2
V1	Transmission output (0-10VDC): 1
V2	Transmission output (0-10VDC): 2
R1	Alarm output: 1
R2	Alarm output: 2
R4	Alarm output: 4
0	100-240VAC 50/60Hz
1	24VDC
10	Universal input
40	Pulse input (※option)
CN-6	Isolated Converter

SENSORS
CONTROLLERS
MOTION DEVICES
SOFTWARE
(J) Temperature Controllers
(K) SSRs
(L) Power Controllers
(M) Counters
(N) Timers
(O) Digital Panel Meters
(P) Indicators
(Q) Converters
(R) Digital Display Units
(S) Sensor Controllers
(T) Switching Mode Power Supplies
(U) Recorders
(V) HMIs
(W) Panel PC
(X) Field Network Devices

CN-6000 Series

■ Specifications

Model		CN-610□-□	CN-640□-□
Power supply	AC voltage	100-240VAC ~ 50/60Hz	
	DC voltage	24VDC=	
Allowable voltage range		90 to 110% of rated voltage	
Power consumption	AC voltage	Max. 8VA	
	DC voltage	Max. 3W	
Display method		12-segment (selectable red, green, yellow) graphic bar and input type/unit display part (red) with LCD method	
Character size		Display part: 6.4×11.0mm (12-segment), input type/unit display part: 1.4×2.75mm (unit)	
Input type	RTD	JPt100Ω, DPt100Ω, DPt50Ω, Cu50Ω, Cu100Ω	—
	Thermocouple	K, J, E, T, R, B, S, N, C, L, U, PLII	—
	Analog	• Voltage: -50.0-50.0mV, -199.9-200.0mV, -1.000-1.000V, -1.00-10.00V • Current: 0.00-20.00mA, 4.00-20.00mA	—
	Pulse input	—	0 to 50.00kHz (input impedance: 10kΩ)
Output	Transmission output	0-20mA (adjustable output range), load resistance max. 600Ω (accuracy: ±0.3 F.S., resolutions: 8000) 0-10VDC= (adjustable output range), load resistance min. 10kΩ (accuracy: ±0.3 F.S., resolutions: 8000)	
	Alarm output	1-point: relay contact capacity 250VAC 5A 1a 2-point: relay contact capacity 250VAC 3A 1c 4-point: relay contact capacity 250VAC 5A 1a	
Display accuracy		±0.2%F.S. ±1-digit (25±5°C), ±0.3%F.S. ±1-digit (-10 to 20°C, 30 to 50°C) ※CN-610□-□: for TC, the input below -100°C is ±0.4%F.S. ±1-digit (TC-T, TC-U is min. ±2.0°C)	
Setting method		Set by front keys	
Sampling cycle		Analog input: 100ms, temperature sensor input: 250ms	—
Display cycle		—	Same with pulse input cycle When pulse input cycle is over 10 sec, it is updated by every 10 sec
Dielectric voltage		2000VAC 50/60Hz for 1 min (between input terminal and power terminal)	
Vibration		0.75mm amplitude at frequency of 5 to 55Hz (for 1 min) in each X, Y, Z direction for 2 hours	
Insulation resistance		Over 100MΩ (at 500VDC megger)	
Noise immunity		±2kV the square wave noise (pulse width 1μs) by noise simulator	
Memory retention		Approx. 10 years (non-volatile semiconductor memory type)	
Environment	Ambient temperature	-10 to 50°C, storage: -20 to 60°C	
	Ambient humidity	35 to 85%RH, storage: 35 to 85%RH	
Approval		CE	—
Weight※1		Approx. 301g (approx. 160g)	Approx. 340g (approx. 200g)

※1: The weight includes packaging. The weight in parenthesis is for unit only.

※Environment resistance is rated at no freezing or condensation.

Input Type and Range

Input type selection switch

• 8-pin

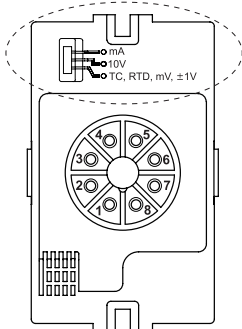

• 11-pin

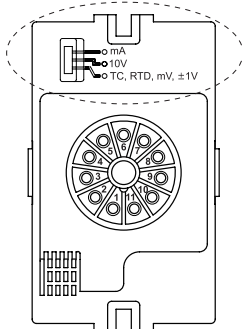

- mA: Select it for 0(4)-20mA input
- 10V: Select it for -1V-10V input
- TC, RTD, mV, ±1V: Select it for TC, RTD or ±1mV, V input
- ※The pulse input model (CN-640□-□) does not have this input type selection switch.
- This product is multi-input. Select the desired input type by the input type selection switch and select the input type at [I N P]
- The selection of the input type selection switch and that of [I N P] should be same to display correct value. Factory default is 4-20mA.

© CN-610□-□ (universal input)

Input type	Parameter	Input range (°C)	Input range (°F)	
Thermocouple	K(CA)	ε[CK 1]	-200 to 1350	-328 to 2462
		ε[CK 2]	-199.9 to 999.9	-328 to 1832
	J(IC)	ε[C-J]	-199.9 to 800.0	-328 to 1472
	E(CR)	ε[C-E]	-199.9 to 800.0	-328 to 1472
	T(CC)	ε[C-t]	-199.9 to 400.0	-199.9 to 752.0
	B(PR)	ε[C-b]	400 to 1800	752 to 3272
	R(PR)	ε[C-R]	0 to 1750	32 to 3182
	S(PR)	ε[C-S]	0 to 1750	32 to 3182
	N(NN)	ε[C-N]	-200 to 1300	-328 to 2372
	C(W5)	ε[C-C]	0 to 2300	32 to 4172
	L(IC)	ε[C-L]	-199.9 to 900.0	-328 to 1652
	U(CC)	ε[C-U]	-199.9 to 400.0	-199.9 to 752.0
Platinel II	ε[C-P]	0 to 1390	32 to 2534	
RTD	Cu50Ω	ε[U50]	-199.9 to 200.0	-199.9 to 392.0
	Cu100Ω	ε[U10]	-199.9 to 200.0	-199.9 to 392.0
	JPt100Ω	ε[Pt.1]	-199.9 to 600.0	-328 to 1112
	DPt50Ω	ε[Pt.5]	-199.9 to 600.0	-328 to 1112
	DPt100Ω	ε[Pt.1]	-199.9 to 850.0	-328 to 1530
Analog	Current	0.00 - 20.00mA	ε[MA 1]	-1999 to 9999 (display range depends on the decimal point position)
		4.00 - 20.00mA	ε[MA 2]	
	Voltage	-50.0 - 50.0mV	ε[MV 1]	
		-199.9 - 200.0mV	ε[MV 2]	
		-1.000 - 1.000V	ε[V 1]	
	-1.00 - 10.00V	ε[V 2]		

© CN-640□-□ (pulse input)

Input type	Measuring cycle	Parameter	Range
Pulse	0 to 9.999Hz	Max. 10 sec	-1999 to 9999 (display range is variable according to decimal point position.)
	0 to 99.99Hz	Max. 10 sec	
	0 to 999.9Hz	Max. 10 sec	
	0 to 9.999kHz	Max. 1 sec	
	0 to 50.00kHz	Max. 0.1 sec	

※Pulse input: Non-contact 0 to 50kHz, Contact 0 to 45Hz (displays 0 for below 0.1Hz)

※Input Low Level: 0-1VDC / Input High Level: 5-24VDC

※Duty Ra io: 30 to 70%

※The principle of displaying frequency is converting the time difference between input pulses to the frequency. 1 sec is required to measure 1Hz, and 10 sec is required to measure 0.1Hz. Therefore, it is normal that the lower pulse, the slower response speed. In case of 0Hz, if there are no pulses for over 2 sec, it is programmed to display 0Hz to prevent slow response speed.

SENSORS
CONTROLLERS
MOTION DEVICES
SOFTWARE
(J) Temperature Controllers
(K) SSRs
(L) Power Controllers
(M) Counters
(N) Timers
(O) Digital Panel Meters
(P) Indicators
(Q) Converters
(R) Digital Display Units
(S) Sensor Controllers
(T) Switching Mode Power Supplies
(U) Recorders
(V) HMIs
(W) Panel PC
(X) Field Network Devices

CN-6000 Series

■ Dimensions

(unit: mm)

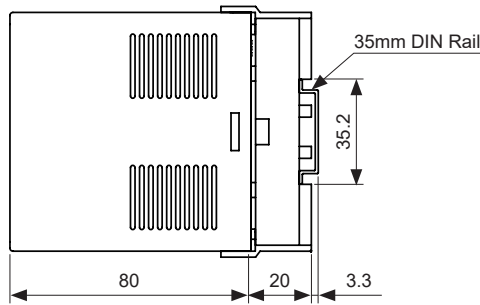
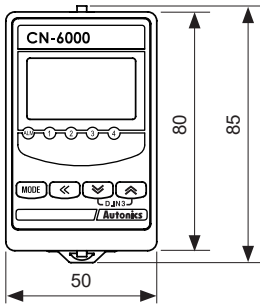

● 8-pin socket

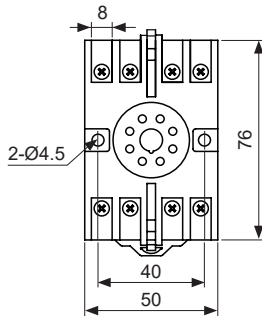

● 11-pin socket

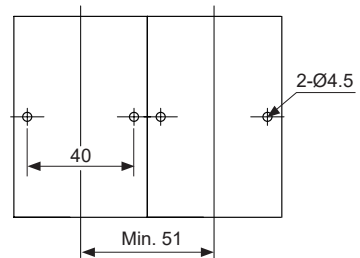
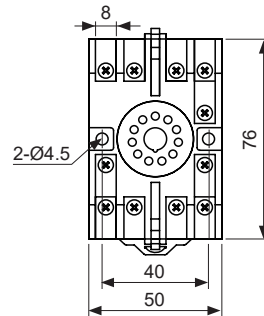

■ Unit Description

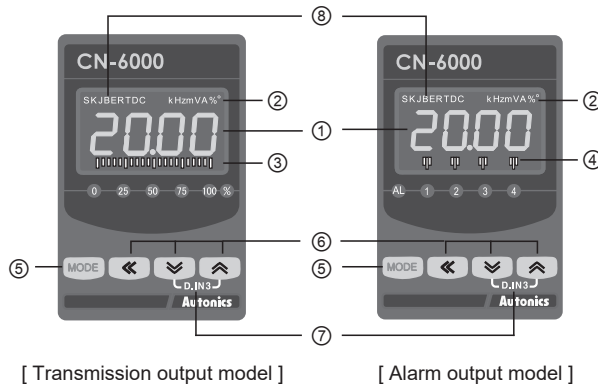

- ① Display part (selectable red, green, yellow)
 - Run mode: Displays current measured value.
 - Set mode: Displays parameters.
- ② Unit display part (red)
- ③ Output scale bar: For transmission output mode, displays output as % by scale bars.
- ④ Alarm output indicator: Turns ON when the alarm output is on.
- ⑤ **MODE** key: Used to enter parameter set mode, move to parameters, save SV and return to RUN mode.
- ⑥ key: Used to change parameter SV.
- ⑦ **D.IN3**: Press the and keys for 3 sec at the same time, it operates the set function (alarm clear, display hold, zero-point adjustment) at [d1 - k].
- ⑧ Input type (only for CN-610□-□): Turns ON the selected temperature sensor type at [i N - p] parameter.
 (In case of thermocouple type, L, N, U, P types are not displayed.
 In case of RTD type, RTD is displayed.)

■ Connections

◎ CN-610 □-□

● 8-pin

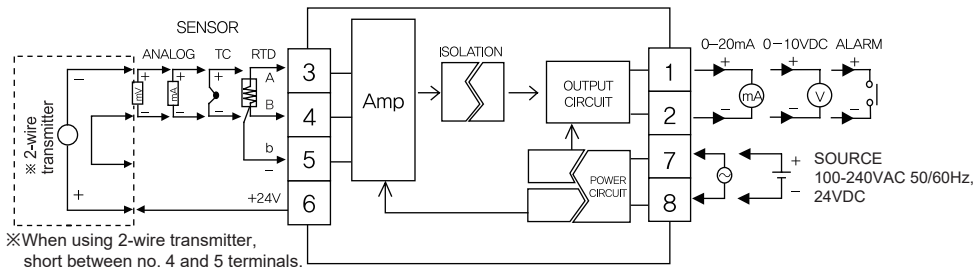

● 11-pin

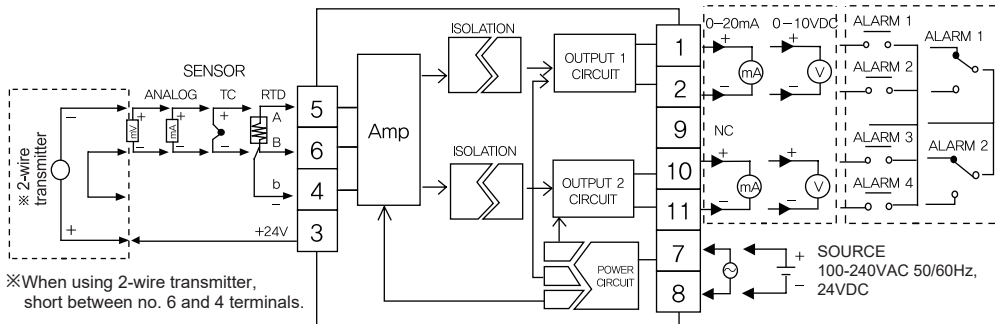

◎ CN-640 □-□

● 8-pin

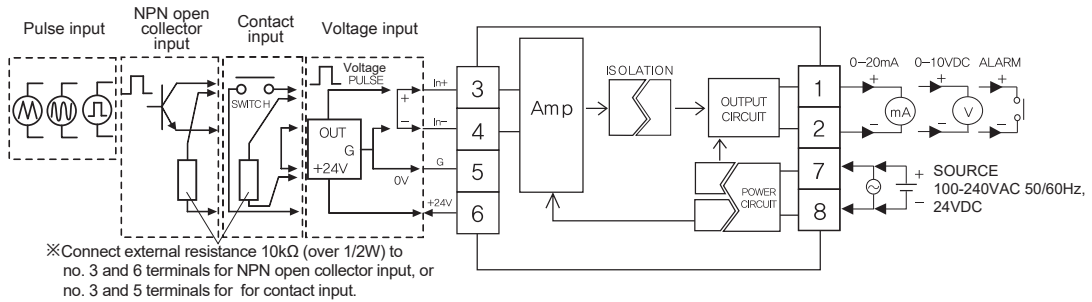

● 11-pin

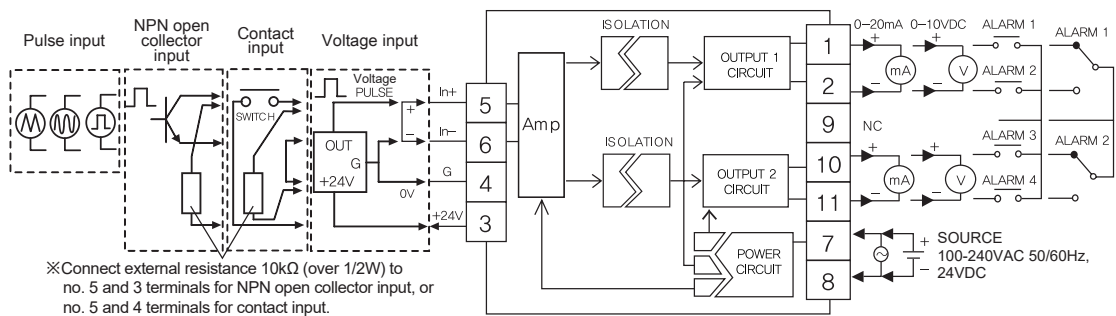

SENSORS
CONTROLLERS
MOTION DEVICES
SOFTWARE
(J) Temperature Controllers
(K) SSRs
(L) Power Controllers
(M) Counters
(N) Timers
(O) Digital Panel Meters
(P) Indicators
(Q) Converters
(R) Digital Display Units
(S) Sensor Controllers
(T) Switching Mode Power Supplies
(U) Recorders
(V) HMIs
(W) Panel PC
(X) Field Network Devices

CN-6000 Series

■ Functions

◎ Alarm [AL-1, AL-2, AL-3, AL-4]

This product has 1, 2 or 4 alarms to operate individually when the value is too high or low.

Alarm function is set by the combination of alarm operation and alarm option.

To clear alarm, use digital input function (setting as $AL.RE$ for $d1-k$) or turn the power OFF and ON.

※ For the model without alarm output (CN-6□□-C1/C2/V1/V2), these parameters are not displayed.

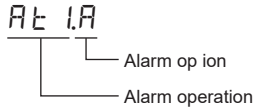

※1: Only for CN-610□-□.

※H: alarm output hysteresis

● Alarm operation

Mode	Name	Alarm operation	Description
AL0	—	—	No alarm operation
AL1	High limit alarm		PV ≥ alarm temperature, alarm is ON
AL2 ^{※1}	Low limit alarm		PV ≤ alarm temperature, alarm is ON
SbAL	Sensor break alarm	—	It will be ON when it detects sensor disconnection. Sensor break alarm does not have alarm option.

● Alarm option

Mode	Name	Descriptions
ALa	Standard alarm	If it is an alarm condition, alarm output is ON. Unless an alarm condition, alarm output is OFF.
ALb	Alarm latch	If it is an alarm condition, alarm output is ON. Before clearing the alarm, an ON condition is latched. (Holding the alarm output)
ALc	Standby sequence	First alarm condition is ignored. From the second alarm condition, standard alarm operates. When power is ON and it is an alarm condition, it is ignored. From the second alarm condition, standard alarm operates.
ALd	Alarm latch and standby sequence	If it is an alarm condition, it operates both alarm latch and standby sequence. When power is ON and it is an alarm condition, it is ignored. From the second alarm condition, alarm latch operates.

◎ Alarm output hysteresis [Program mode: A-HY]

Set the interval of ON/OFF alarm output.

The set hysteresis is applied to AL1 to AL4 and it is as below.

E.g.) A-HY 4

high limit alarm value: 800°C

low limit alarm value: 200°C

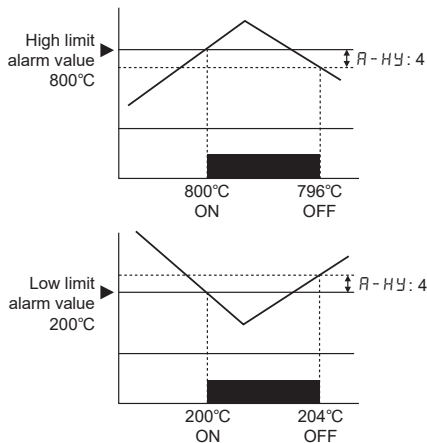

◎ High/Low peak monitoring [Monitoring mode: HPEK, LPEK]

This function is to save high/low peak to check the invisible abnormal condition of system at [HPEK] or [LPEK] in monitoring mode.

When the high/low peak is out of the temperature range, it displays HHHH or LLLL.

To initialize high/low peak, press the \checkmark , \boxtimes keys at the same time for 3 sec at [HPEK] or [LPEK].

In this case, peak value is the present input value.

◎ Error

※1: Only for CN-610□-□.

Display	Descriptions	Troubleshooting
LLLL	Flashes when measured sensor input is lower than the temperature range.	When input is moved within the temperature range, it is cleared.
HHHH	Flashes when measured sensor input is higher than the temperature range	
bURN ^{※1}	Flashes when the sensor is break or not connected.	Check temperature sensor connection.
ERR	Flashes when there is error to SV.	Check set conditions and re-set it.
ERR ^{※1}	Flashes when [INP] setting and input type selection switch setting are not same.	Check input type.

◎ Parameter initialization

To initialize all parameter as factory default, press the **MODE** and **⏏** keys at the same time in RUN mode and it enters initialization parameter.

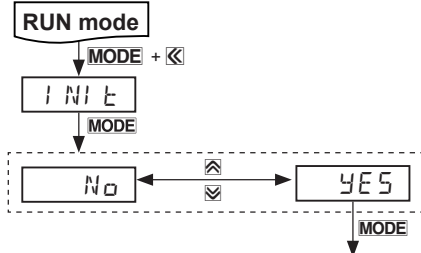

※Parameter initialization is available only when lock [L o C K] is set as OFF.

◎ Temperature unit [Program mode: UNIT]

Temperature unit (°C/°F) is selectable. When changing temperature unit, user input range, display scale, output scale, alarm SV are initialized. You should set the parameters again for your purpose.

※When selecting analog input, this parameter [UNIT] is not displayed.

◎ Front display unit [Program mode: dUNIT]

- When selecting analog input, select the unit (% , mV , V , mA , A , °C , °F) of display value. (CN-610□-□)
- When selecting pulse input, select the unit (kHz , Hz , %) of display value. (CN-640□-□)
- When not displaying unit, set OFF and it turns OFF all indicators.

◎ User input range

[Program mode: L-RG, H-RG]

When selecting analog input, you can set the input range for your purpose. Set low limit input value [L-RG] and high limit input value [H-RG] to limit the input range.

- Setting range: Low limit input value [L-RG] +20% F.S. < High limit input value [H-RG]

◎ Decimal point [Program mode: dP]

It is able to change decimal point position for high/low limit scale value. It changes decimal point position of display value.

◎ Display scale

[Program mode: L-SC, H-SC]

For analog input, this function is to set (-1999 to 9999) for particular high/low limit value in order to display high/low limit value of measurement input. If measurement inputs are 'a' and 'b' and particular values are 'A' and 'B', it will display a=A, b=B as below graphs.

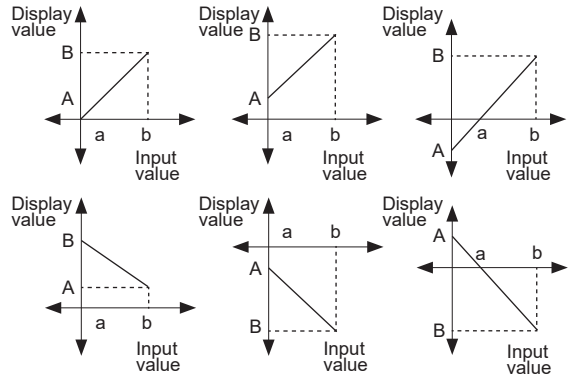

Display scale function is able to change display value for max./min. measured input by setting high limit scale [H-SC] and low limit scale [L-SC] in program mode.

E.g.) Set high/low scale value (input range is 0 to 10V)

- L-SC = 0.00
- H-SC = 5.00, 10.00, 15.00, 40.00

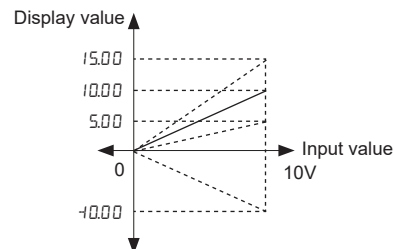

- L-SC = 10.00, H-SC = -10.00

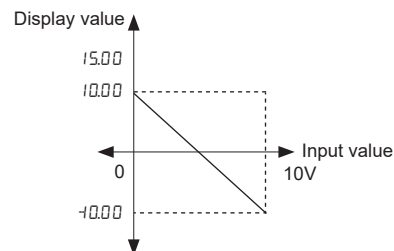

- L-SC = -5.00, H-SC = 5.00

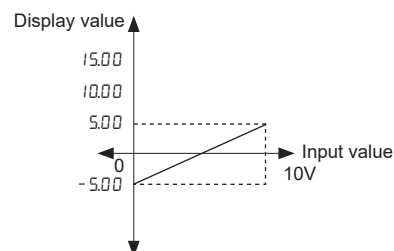

※When changing input type, high/low scale is changed as factory default.

SENSORS
CONTROLLERS
MOTION DEVICES
SOFTWARE
(J) Temperature Controllers
(K) SSRs
(L) Power Controllers
(M) Counters
(N) Timers
(O) Digital Panel Meters
(P) Indicators
(Q) Converters
(R) Digital Display Units
(S) Sensor Controllers
(T) Switching Mode Power Supplies
(U) Recorders
(V) HMIs
(W) Panel PC
(X) Field Network Devices

CN-6000 Series

■ Functions

◎ Input correction [Program mode: $I\ N\ b$]

This function is to correct the error occurring from a thermocouple, a RTD or analog input out of allowable error range of this unit.

This is also available to correct error when a sensor cannot contact the subject position by calculating the error temperature.

Variable temperature sensors have accuracy level. Because high accuracy type is expansive, standard thermocouples are generally used.

In this case, temperature sensor may occur error.

By executing this function, you can get more accurate temperature.

When executing input correction function, you should measure the error from a sensor accurately.

If the measured error is not correct, error may be greater.

E.g.)When measured temperature is 4°C and actual temperature is 0°C. Set $I\ N\ b$ as -4, and display value is 0°C.

◎ Transmission output range

[Program mode: $L\ o\ R\ \square, H\ o\ R\ \square$]

This function is to set output scale and range for display value for transmission output.

When the input value set at $L\ o\ U\ \square / L\ o\ U\ \square$ is displayed, the output value set at $L\ o\ R\ \square / L\ o\ R\ \square$ is transmitted.

When the input value set at $H\ o\ U\ \square / H\ o\ U\ \square$ is displayed, the output value set at $H\ o\ R\ \square / H\ o\ R\ \square$ is transmitted.

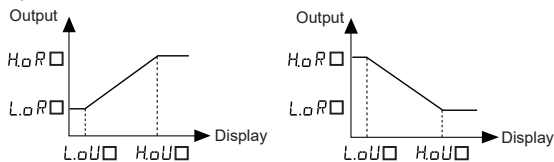

※Relation among input range, user input range, display scale, transmission scale, and output range.

The below figure is the example for 4 to 20mA input.

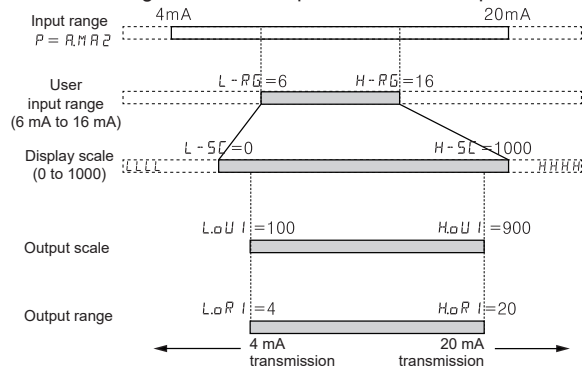

When display value is 100, it outputs 4mA.

When display value is 900, it outputs 20mA.

◎ Bar display channel

[Program mode: $b\ A\ R$, User level: $H\ I\ G\ H$]

This function is to select OUT1 or OUT2 for Bar display of transmission output scale.

※Only for the model which has two transmission outputs (CN-6□□□-C2/V2), this parameter is displayed.

◎ Input and transmission output extension

[Program mode: $E\ X\ J\ \square$]

This function is to extend analog input and 4 to 20mA, 0-10VDC transmission output to 5% or 10% range.

The below table is the case of 4 to 20mA transmission output range setting.

Mode	Operation
$0\ P$	Outputs 4 to 20mA within analog input range.
$5\ P$	Outputs 3.2 to 20.8mA for 5% out of the analog input range.
$10\ P$	Outputs 2.4 to 21.6mA for 10% out of the analog input range.

※This parameter is not displayed for not transmission output (4-20mA, 0-10V) model, or for selecting temperature sensor input.

※Below 0mA, 0VDC cannot extend.

※±1VDC, 10VDC input are available to extend only 5%.

◎ Input special function

[Program mode: $I\ N\ S\ F$]

When selecting analog input, this function is to display the calculated actual value by square, root ($\sqrt{\quad}$), or two unit function (TUF) as display value.

Parameter	Functions	Graph	Applications
$L\ I\ N$	Outputs as input value		Standard characteristics. Input for linearity.
$R\ o\ o\ t$	Outputs the rooted ($\sqrt{\quad}$) input value		Used for measuring flows by pressure signal.
$S\ q\ u\ a\ r\ e$	Outputs the squared input value		Used for outputting differential pressure by flow signal.
$t\ u\ f$	Refer to '◎ Atmospheric pressure (0) setting for Two Unit Function'		

※Display value and mA output value for $S\ q\ u\ a\ r\ e$

$$\text{Display value} = \left\{ \left(\frac{\text{Input value} - L - R\ G}{H - R\ G - L - R\ G} \right)^2 \times (H - S\ C - L - S\ C) \right\} + L - S\ C$$

(output value)

※Display value and mA output value for $R\ o\ o\ t$

$$\text{Display value} = \left\{ \sqrt{\frac{\text{Input value} - L - R\ G}{H - R\ G - L - R\ G}} \times (H - S\ C - L - S\ C) \right\} + L - S\ C$$

(output value)

※This function is only for CN-610□-□.

⊙ Atmospheric pressure (0) setting for Two Unit Function

[Program mode: $DPSt$, $INSF: EUF$]

When connecting a pressure sensor, compound pressure which is below atmospheric pressure (0) is for vacuum as mmHg and which is atmospheric pressure or over it is for positive pressure as kg/cm^2 .

Atmospheric pressure is $0kg/cm^2$.

When this unit does not display $0kg/cm^2$, you can correct zero-point adjustment function.

When using two unit function, $L5C$ is fixed as 760 .

$L5C$ parameter is displayed but you cannot set this. You can set $H5C$ within 0 to 9999 range.

E.g.) When pressure range is $-760.0mmHg$ to $3.000kg/cm^2$, and pressure transmitter outputs 4-20mA and it outputs 8.00mA for atmospheric pressure(0), set input special function as EUF , $H5C: 3000$, $dP: 0000$, $DPSt: 0000$. This unit displays for 4mA input as 760 , for 8mA input as 0000 and 20mA input as 3000 .

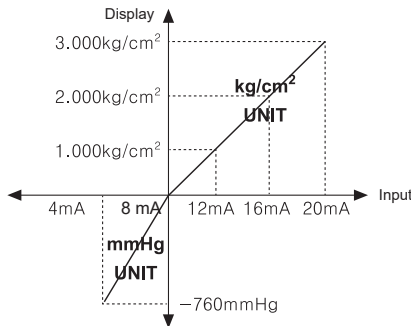

⊗ This function is only for CN-610□□□.

⊙ Span correction

[Program mode: $SPAN$, User level: $HI GH$]

It corrects the error of display value for 100% input.

- Setting range: 0.900 to 1.100

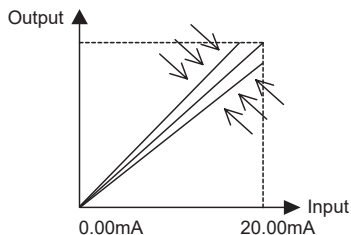

⊙ Digital filter

[Program mode: $AVF/MRVF$, User level: $HI GH$]

Digital filter is able to stably display and output the noise from input line and irregular signals.

Normal average filter AVF displays the averaged N times of input values periodically. Moving average filter $MRVF$ displays the moving averaged N times of input values in real time.

- Setting range: 01 to 16

⊗ When setting as 01, digital filter function does not run.

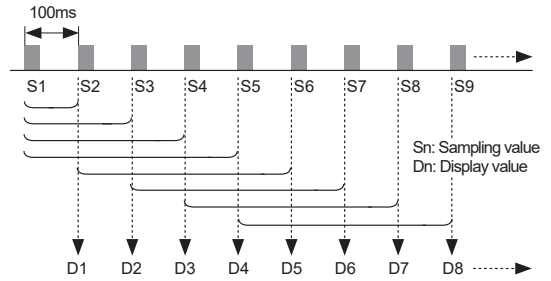

$D1=S1$, $D2=S2$, $D3=S3$: Initial operation before averaging 4

$$D4 = \frac{S1+S2+S3+S4}{4} \quad D5 = \frac{S2+S3+S4+S5}{4}$$

$$D6 = \frac{S3+S4+S5+S6}{4} \quad D7 = \frac{S4+S5+S6+S7}{4}$$

$$D8 = \frac{S5+S6+S7+S8}{4}$$

⊙ Digital input [Program mode: $dI - K$]

By front digital input keys (D.IN3: \boxtimes + \boxtimes for 3 sec), one of three functions executes as the below table.

Function		Operation
$ALRE$	Alarm clear	When alarm is ON in RUN mode, it clears alarm forc bly. (It applies only for alarm latch, alarm latch and standby sequence options.) Alarm clear operates only when the value is out of the alarm value range. After clearing alarm, alarm operates its option normally. ⊗ For the model without alarm output (CN-6□□□-C1/C2/V1/V2), this parameter is not displayed.
$HoLd$	Display HOLD	Temporarily indicated value is stopped in order to confirm indicated value in unstable input.
$ZERo$	Zero-point adjustment	Set preset display value as 0. This function is related with input correction [INb]. When executing zero adjustment function in display value as 4, input correction value INb is set -4 automatically.

SENSORS
CONTROLLERS
MOTION DEVICES
SOFTWARE
(J) Temperature Controllers
(K) SSRs
(L) Power Controllers
(M) Counters
(N) Timers
(O) Digital Panel Meters
(P) Indicators
(Q) Converters
(R) Digital Display Units
(S) Sensor Controllers
(T) Switching Mode Power Supplies
(U) Recorders
(V) HMIs
(W) Panel PC
(X) Field Network Devices

CN-6000 Series

■ Functions

◎ Display color [Program mode: $\llcorner\lrcorner\lrcorner$]

This function is to change display color for occurring error, operating alarm automatically. User can check the status of this unit directly.

※ Color of monitoring mode, program mode is red.

● EVENT: When operating alarm and displaying

$HHHH, LLLL, bURN, ERR$

Parameter	Display color	
SV	RUN	EVENT
REd	Red	Red
GRN	Green	Green
$YELo$	Yellow	Yellow
$R--G$	Red	Green
$G--R$	Green	Red

◎ Alarm output for disconnecting input sensor [Program mode: $bURN$]

When disconnecting input sensor, you can set the status of transmission output.

It flashes $bURN$ and it outputs the set value of $HHHH$ or $LLLL$.

For transmission output, it outputs the set max./min. value of I/O expansion function.

Parameter	SV	Transmission output (4-20mA)	Alarm output	
$bURN$	oN	20mA	High limit alarm ON	Low limit alarm OFF
	oFF	4mA	High limit alarm OFF	Low limit alarm ON

※ This function is only for CN-610□-□.

◎ Lock [Program mode: $L\lrcorner\lrcorner$]

It limits to check parameter set value and to change it.

	oFF	$L\lrcorner\lrcorner 1$	$L\lrcorner\lrcorner 2$
Program mode	●	◐	○
Monitoring mode	●	●	◐

●: Enable to check/set

◐: Enable to check, disable to set

○: Disable to check/set

※ In $L\lrcorner\lrcorner 2$, only $L\lrcorner\lrcorner K$ parameter displays in program mode.

Monitoring Mode

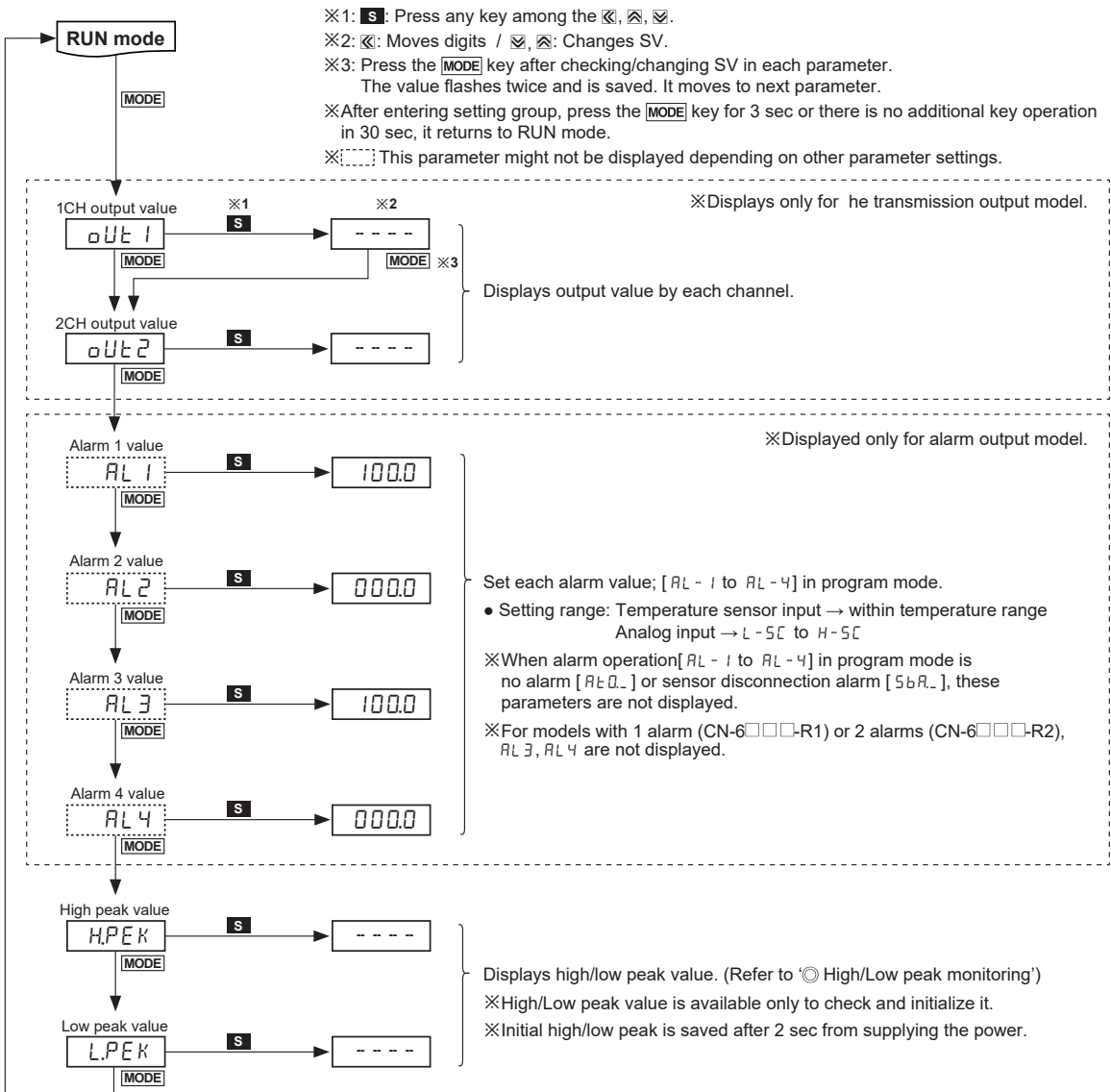

SENSORS
CONTROLLERS
MOTION DEVICES
SOFTWARE
(J) Temperature Controllers
(K) SSRs
(L) Power Controllers
(M) Counters
(N) Timers
(O) Digital Panel Meters
(P) Indicators
(Q) Converters
(R) Digital Display Units
(S) Sensor Controllers
(T) Switching Mode Power Supplies
(U) Recorders
(V) HMIs
(W) Panel PC
(X) Field Network Devices

CN-6000 Series

■ Program Mode

◎ CN-610□-□ (universal input)

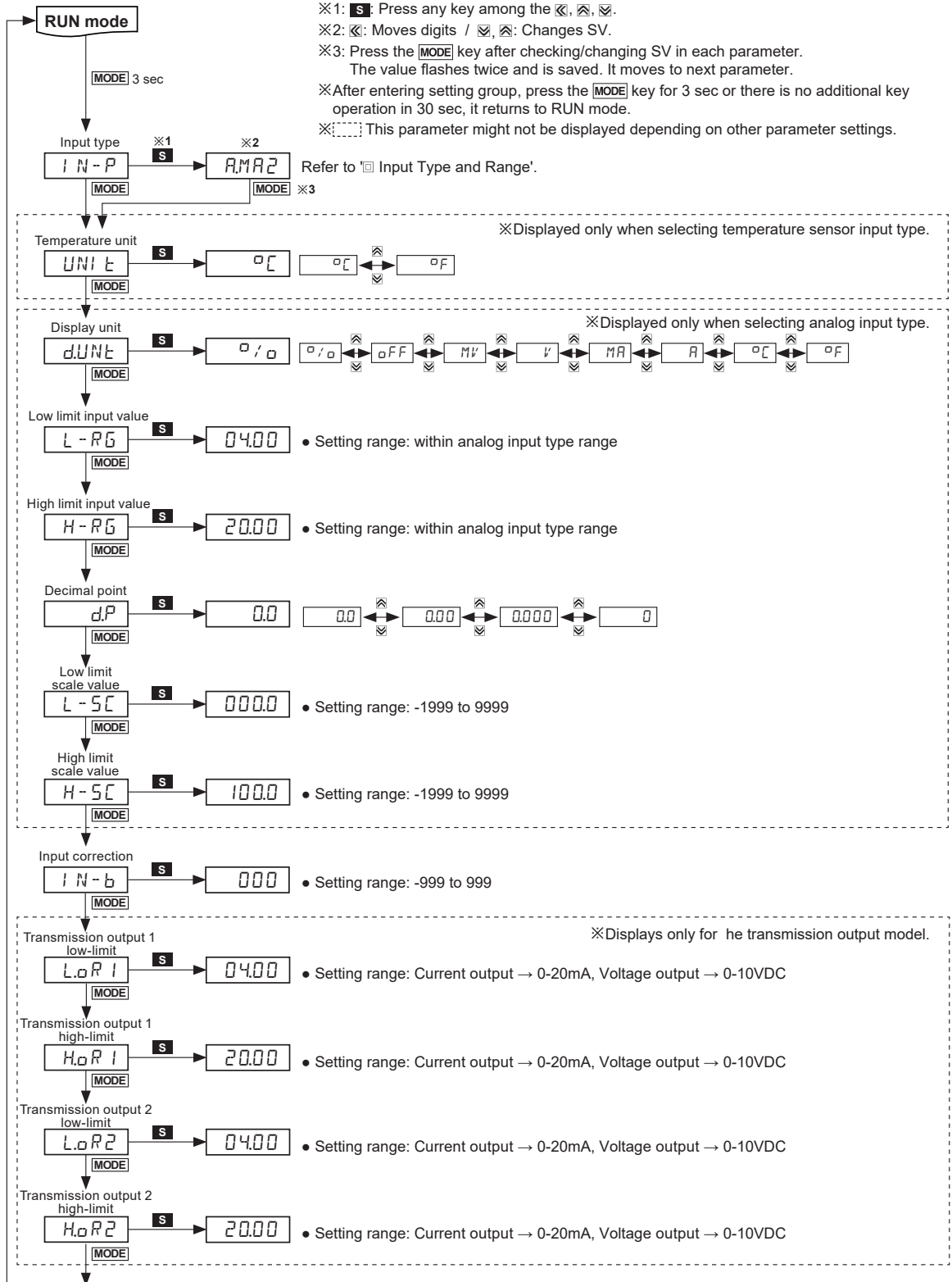

Isolated Converter

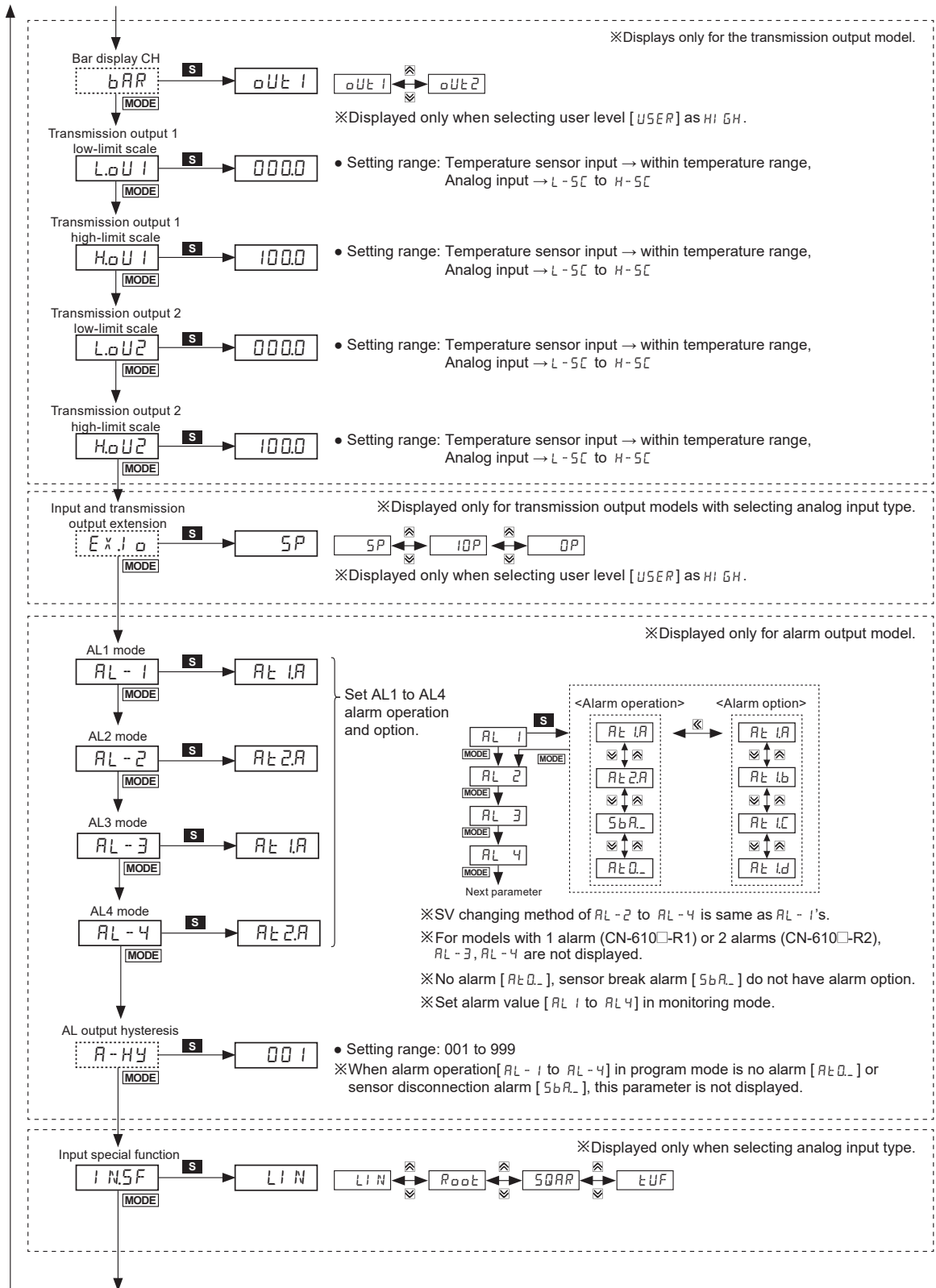

SENSORS
CONTROLLERS
MOTION DEVICES
SOFTWARE
(J) Temperature Controllers
(K) SSRs
(L) Power Controllers
(M) Counters
(N) Timers
(O) Digital Panel Meters
(P) Indicators
(Q) Converters
(R) Digital Display Units
(S) Sensor Controllers
(T) Switching Mode Power Supplies
(U) Recorders
(V) HMIs
(W) Panel PC
(X) Field Network Devices

CN-6000 Series

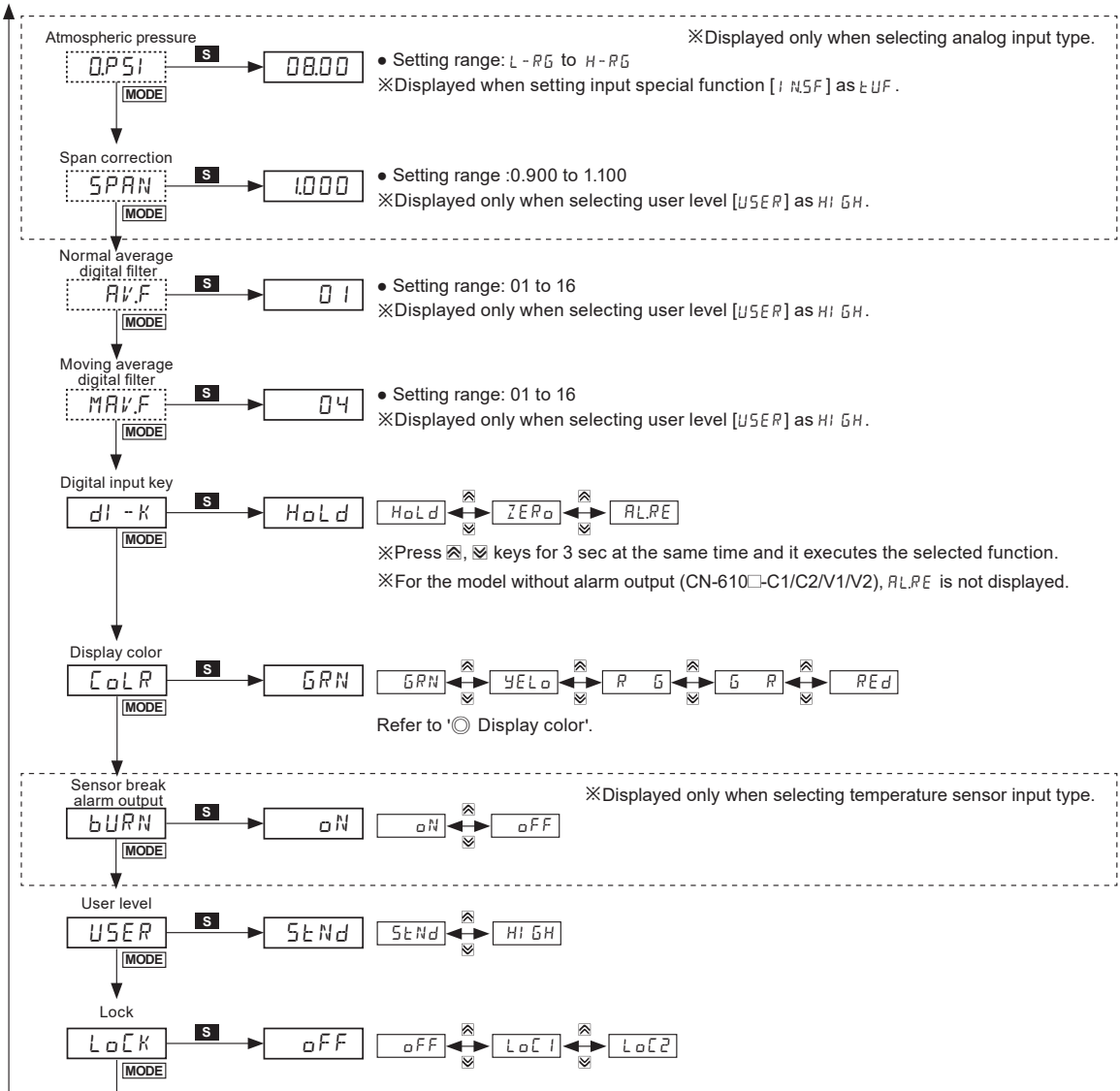

© CN-640□-□ (pulse input)

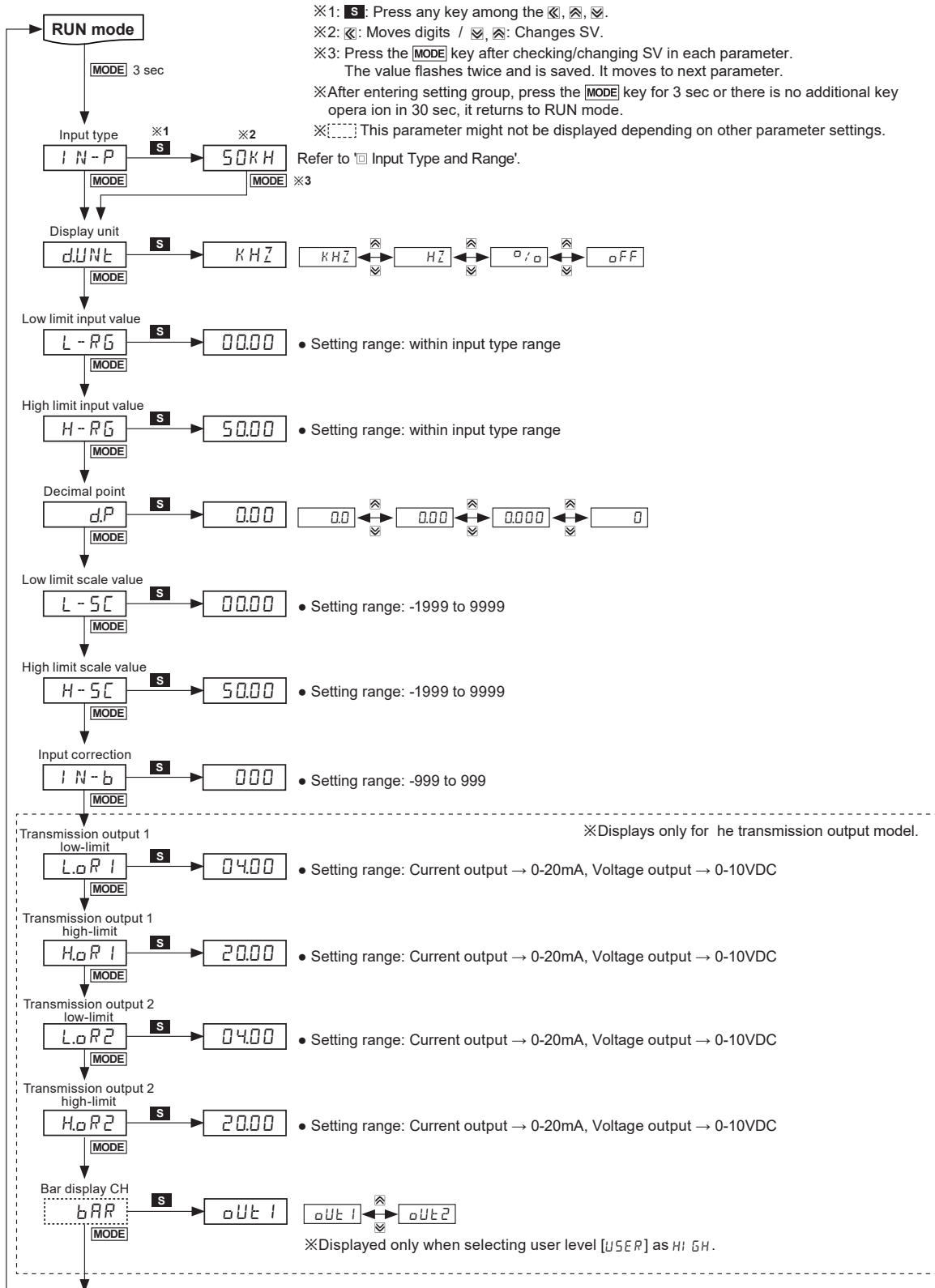

SENSORS
CONTROLLERS
MOTION DEVICES
SOFTWARE
(J) Temperature Controllers
(K) SSRs
(L) Power Controllers
(M) Counters
(N) Timers
(O) Digital Panel Meters
(P) Indicators
(Q) Converters
(R) Digital Display Units
(S) Sensor Controllers
(T) Switching Mode Power Supplies
(U) Recorders
(V) HMIs
(W) Panel PC
(X) Field Network Devices

CN-6000 Series

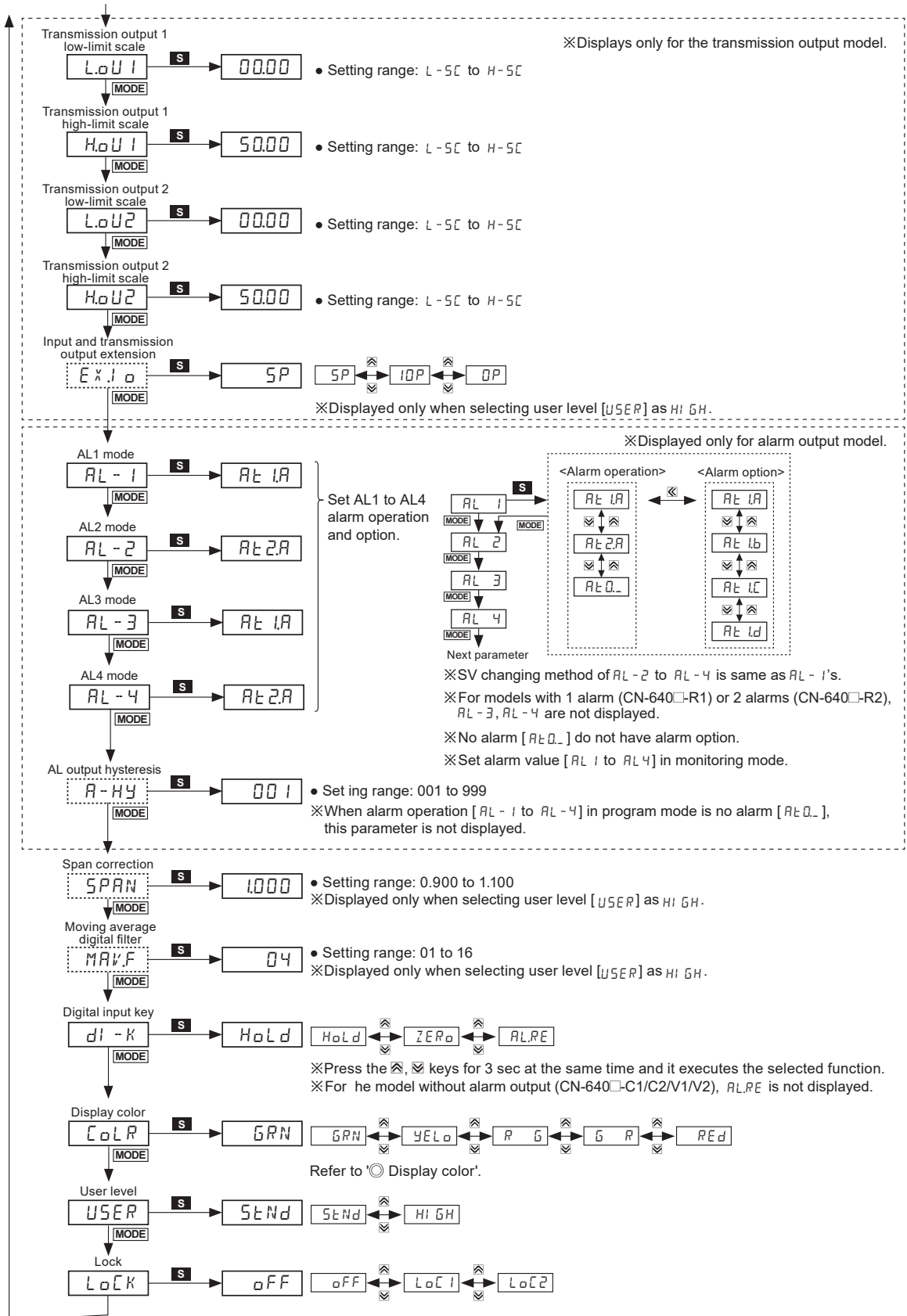

■ Factory Default

◎ CN-610□-□ (universal input)

● Monitoring mode

Parameter	Default	Parameter	Default	Parameter	Default	Parameter	Default
oU _{t1}	----	AL1	1000	AL3	1000	HPEK	----
oU _{t2}	----	AL2	0000	AL4	0000	LPEK	----

● Program mode

Parameter	Default	Parameter	Default	Parameter	Default	Parameter	Default
IN-P	AMA2	LOR1	04.00 ^{※1} 00.00 ^{※2}	EXJO	SP	SPAN	1.000
UNIt	°C	HOR1	20.00 ^{※1} 10.00 ^{※2}	AL-1	AL1A	AVF	01
dUNIt	°/o	LOR2	04.00 ^{※1} 00.00 ^{※2}	AL-2	AL2A	MAVF	04
L-RG	04.00	HOR2	20.00 ^{※1} 10.00 ^{※2}	AL-3	AL1A	dl-K	HoLd
H-RG	20.00	bAR	oU _{t1}	AL-4	AL2A	CoLR	GRN
dP	00	LoU1	0000	A-HY	001	bURN	oN
L-5C	0000	HoU1	1000	INSF	LIN	USER	StNd
H-5C	1000	LoU2	0000	OP51	0800	LoCK	oFF
IN-b	000	HoU2	1000				

※1: Displayed only for current transmission output, alarm output model (CN-610□-C1/C2/R1/R2/R4).

※2: Displayed only for voltage transmission output model (CN-610□-V1/V2).

◎ CN-640□-□ (pulse input)

● Monitoring mode

Parameter	Default	Parameter	Default	Parameter	Default	Parameter	Default
oU _{t1}	----	AL1	0000	AL3	1000	HPEK	----
oU _{t2}	----	AL2	0000	AL4	1000	LPEK	----

● Program mode

Parameter	Default	Parameter	Default	Parameter	Default	Parameter	Default
IN-P	50KH	LOR1	04.00 ^{※1} 00.00 ^{※2}	HoU2	5000	MAVF	04
dUNIt	KHZ	HOR1	20.00 ^{※1} 10.00 ^{※2}	EXJO	SP	dl-K	HoLd
L-RG	0000	LOR2	04.00 ^{※1} 00.00 ^{※2}	AL-1	AL1A	CoLR	GRN
H-RG	5000	HOR2	20.00 ^{※1} 10.00 ^{※2}	AL-2	AL1A	USER	StNd
dP	000	bAR	oU _{t1}	AL-3	AL1A	LoCK	oFF
L-5C	0000	LoU1	0000	AL-4	AL1A		
H-5C	5000	HoU1	5000	A-HY	001		
IN-b	000	LoU2	0000	SPAN	1000		

※1: Displayed only for current transmission output, alarm output model (CN-640□-C1/C2/R1/R2/R4).

※2: Displayed only for voltage transmission output model (CN-640□-V1/V2).

■ Proper Usage

- For connecting the power, use a crimp terminal (M3.5, max. 7.2mm).
- The connection of this unit should be separated from the power line and high voltage line in order to prevent inductive noise.
- Install a power switch or a circuit breaker to supply or cut off the power.
- Switch or circuit breaker should be installed nearby users for convenient control.
- Do not use this unit near the high frequency instruments (high frequency welding machine & sewing machine, large capacity SCR controller).
- When supplying input, if HHHH or LLLL is displayed, measured input may have problem. Turn off the power and check the line.
- This product may be used in the following environments.
 - ① Indoor
 - ② Pollution degree 2
 - ③ Altitude max. 2,000m
 - ④ Installation category II
- Failure to follow these instructions may result in product damage.

SENSORS
CONTROLLERS
MOTION DEVICES
SOFTWARE
(J) Temperature Controllers
(K) SSRs
(L) Power Controllers
(M) Counters
(N) Timers
(O) Digital Panel Meters
(P) Indicators
(Q) Converters
(R) Digital Display Units
(S) Sensor Controllers
(T) Switching Mode Power Supplies
(U) Recorders
(V) HMIs
(W) Panel PC
(X) Field Network Devices